

	1) Antisismi suspension	2) MRU	3) Knurled nut	4) Elios Tubular	5) BFØ6	6) TBØ4	7) Exstension Elios	8) MR	9) Extended Nut
Elements in the Packaging	x6	x24	x30	x12	x12	x48	x6	x24	x6
Elements for assembling 1 kit	x1	x4	x5	x2	x2	x8	x1	x4	x1

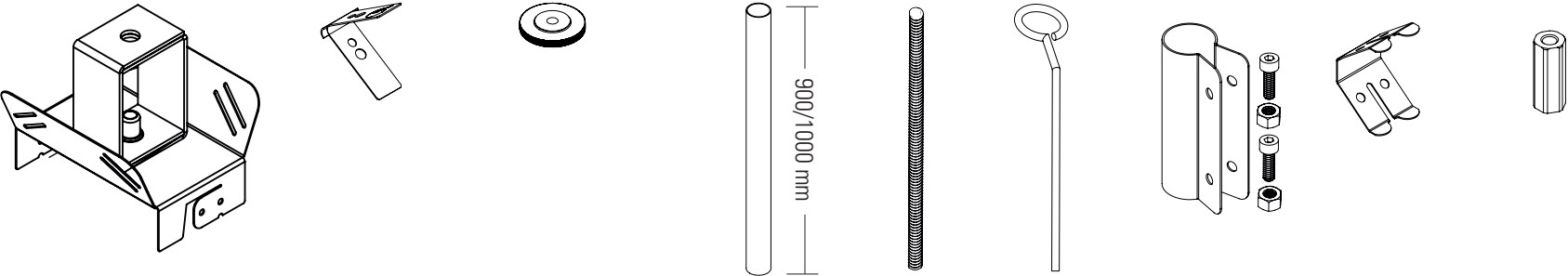

N.B. Elements 2 and 3 are supplied in sealed transparent bag , where the quantities for assembling a **single kit** are contained inside

1- Anti-seismic suspension

Seismic suspension assembly phase

Insert the MRU element (2) into the slots of the anti-seismic suspension

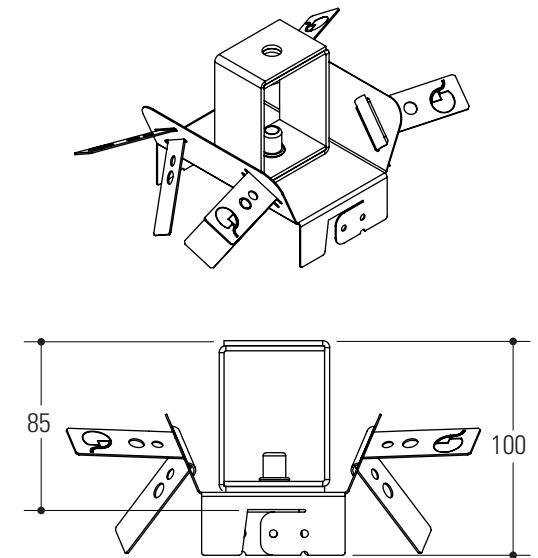
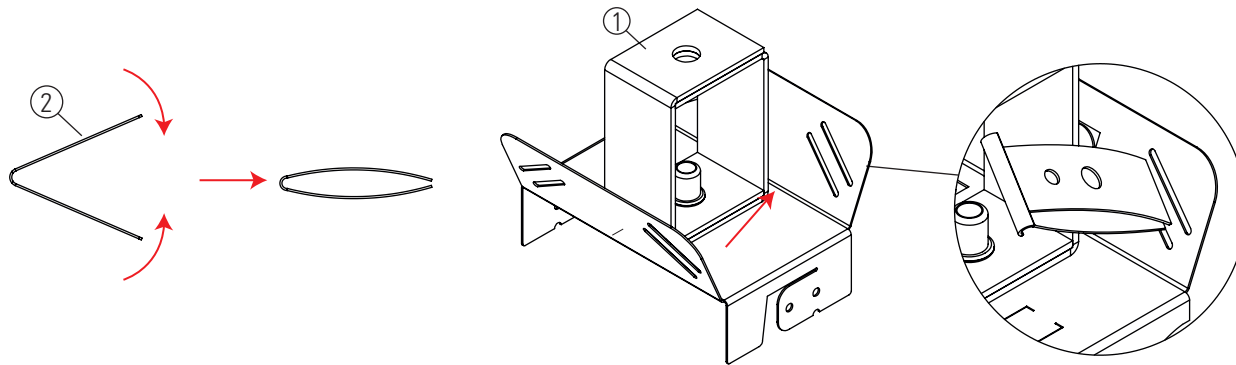

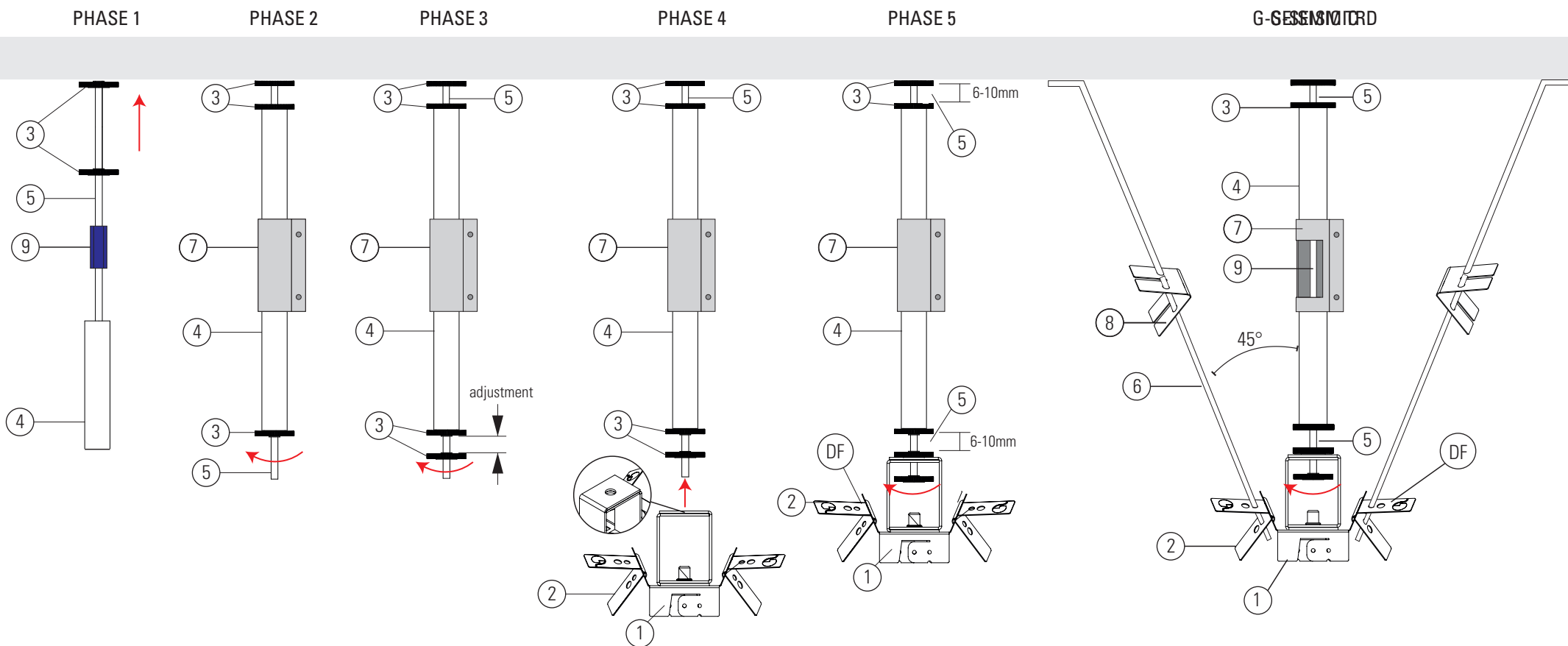

After securing the BFØ6 (5) to the ceiling, screw in the first two threaded washers (3) as in step 1, insert the Elios Tubular (4) from the bottom up and secure it by inserting another threaded washer (3) at the base, as in steps 1 and 2, insert another threaded washer to adjust the height of the system as in steps 2 and 3. Install the pre-assembled Anti-seismic Suspension (1) with the MRU (2), threading the BFØ6 (5) inside the hole located on the top, as indicated in step 4, secure everything by screwing in the last knurled washer as in step 5. The assembly of the G-SEISMIC is completed by fixing the TBØ4 to the floor, only after inserting them in the small hole of the MRU (2) as indicated in phase 5, in the D. F.