

UNI G16 Rails

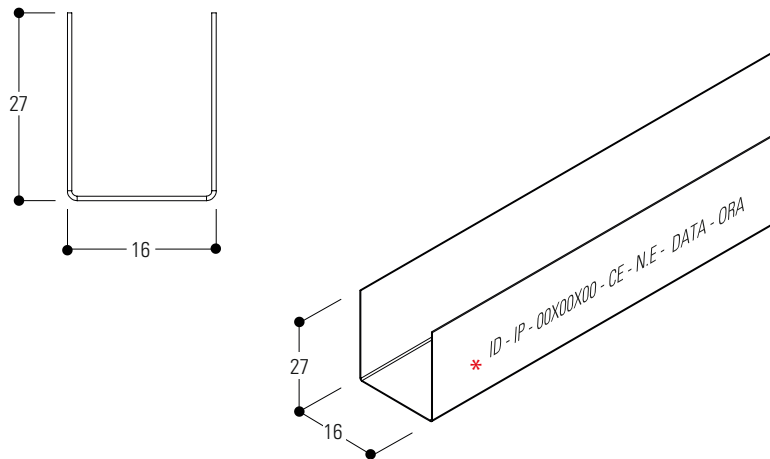

GENERAL DESCRIPTION

The profile, with a U section with equal sides, it is mainly used as a mounting rail (UNI-DIN) and as a perimeter profile. It is suitable for internal use and for the construction of false ceilings, false walls and self-supporting false ceilings, with plasterboard cladding.

MATERIAL USED

The profile is made of carbon steel type **DX51D Z100**, continuously hot-dip galvanized, having a yield strength greater than 300 N/mm² and defined by European standard EN 10346 with a zinc coating of 100 g/m² (higher weight on request) Additional coatings consist of:

- Zinc-aluminium type **DX51D+AZ**: this combination gives the profile excellent corrosion resistance, superior to that of galvanized steel profiles, which makes them suitable for both internal and external use.
- Zinc-magnesium type **DX51D+ZM**: This type of coating gives the profile an extraordinary degree of corrosion protection on the surface and is self-healing on the cut edges, making it suitable for even the harshest environments

REPRESENTATION

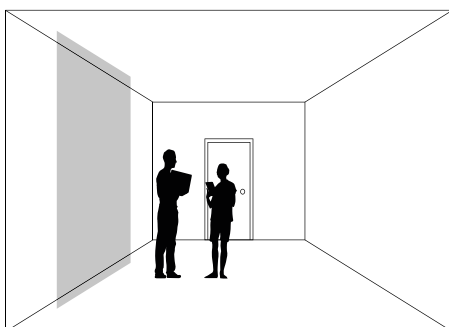

FALSE WALL

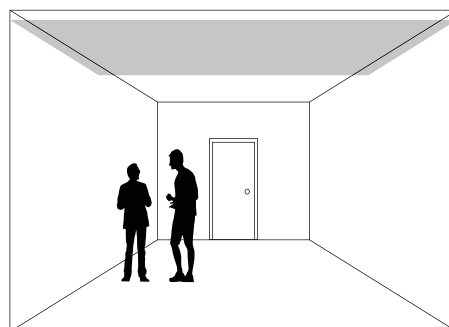

FALSE CEILING

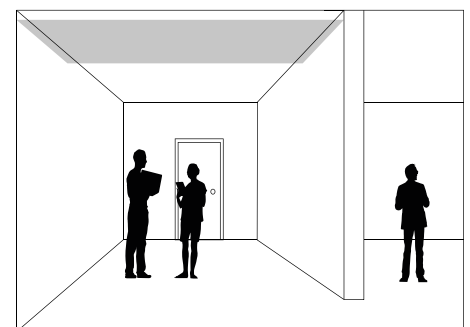

SELF-SUPPORTING CEILING

ADVANTAGES AND APPLICATIONS UNI G16 PROFILE

The **G16** rail has superior versatility and features that make it competitive in its sector; it has 6 mm and 8 mm holes mounted at 250mm pitch that give the rail a precise and adaptable fixing.

-Profile suitable for application with **SP 49/15**

***The information marked individually by ink on the side of each profile are:**

GUERRASIO ID - PRODUCT IDENTIFICATION - DIMENSIONS - CE REGULATION - EUROPEAN NORM - DATE - TIME

ASTENING TO THE FLOOR

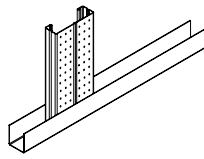

G16 with **SP 49/15**

ASTENING TO THE PERIMETER

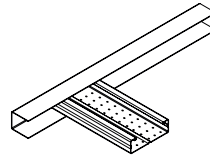

G16 with **SP 49/15**

NORMATIVE REFERENCES

- Construction product in accordance with Regulation (EU) 305/2011
- EC marking in accordance with EN 14195
- Sheet metal quality and coating grade in accordance with EN 10143 and EN 10346

EC MARKING

The products listed in this catalogue are intended for use inside buildings. Each product is provided with a Declaration of Performance (DoP). Reaction to fire: class A1/Durability: class B (building components exposed to variable relative humidity up to 90% and variable temperatures up to 30°C but without corrosive contaminants, except class C5-M products).

PRODUCT STORAGE

Store the packs in a covered areas with a relatively dry atmosphere and at a temperature as constant as possible, in order to avoid condensation which may reduce the state of passivation protecting the galvanised surface. If stored outdoors (not recommended), use a cover that provides perfect protection of the material against the weather (rain, fog, snow), taking care to place the packages at a slight angle. This cover must in any case be such as to allow adequate ventilation (not bringing the two surfaces into direct contact) so that moisture does not accumulate and create condensation.

PACKAGING MATERIAL

The package is made with plastic strips. The pallet is made using plastic strips, wooden supports and laths. The packaging is suitably sized to facilitate handling in warehouses and on construction sites.

TECHNICAL DATA

CHARACTERISTIC	REFERENCE NORM	VALUE	UNIT OF MEASUREMENT
Type	EN 14195	Metal structure	-
Reaction to fire	EN 14195-1A	1	-
Standard thickness	EN 10143	0,6	mm
Thickness tolerance	EN 10143	$\pm 0,07$	mm
Length	EN 14195	3000-4000	mm
Length tolerance	EN 14195	± 4	mm
Protective coating	EN 10346	5 ÷ 12	μm
Yield stress	EN 10143	340	N/mm ²

PACKING AND PALLET SHEET

PACKAGING

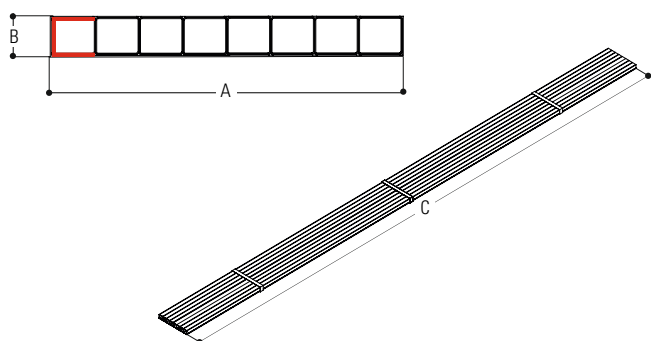

Profile weight	Kg/lm	0,374
	Kg/pc	1,122 (3 lm) / 1,496 (4 lm)
Profile pieces	N°	16
Total per package	lm	48 (3 lm)
	Kg	18,00
	lm	64 (4 lm)
	Kg	24,00
Dimensions	mm	220 (a) 45 (b) 3000 (c) (3 lm)
		220 (a) 45 (b) 4000 (c) (4 lm)

PALLET

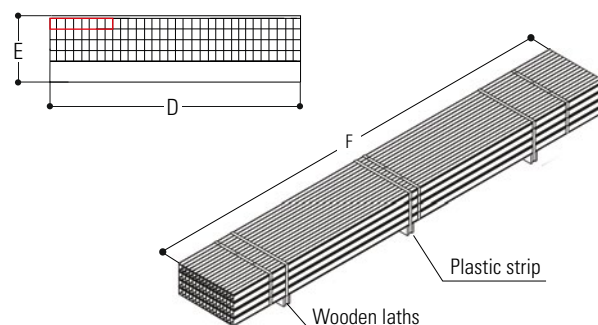

Packages	Pcs	16
Total profiles	Pcs	256
Total per pallets	lm	768 (3 lm)
	Kg	288
	lm	1024 (4 lm)
	Kg	384
Dimensions	mm	590 (d) 190 (e) 3000 (f) (3 lm)
		590 (d) 190 (e) 4000 (f) (4 lm)

Total calculated on 6/10 thickness

N.B. -The weight of the package/pallet is subject to variation depending on the material tolerances described in the table.
 -All technical data and characteristics given in the data sheet are subject to change without notice.