

# UNI G38

## Rails

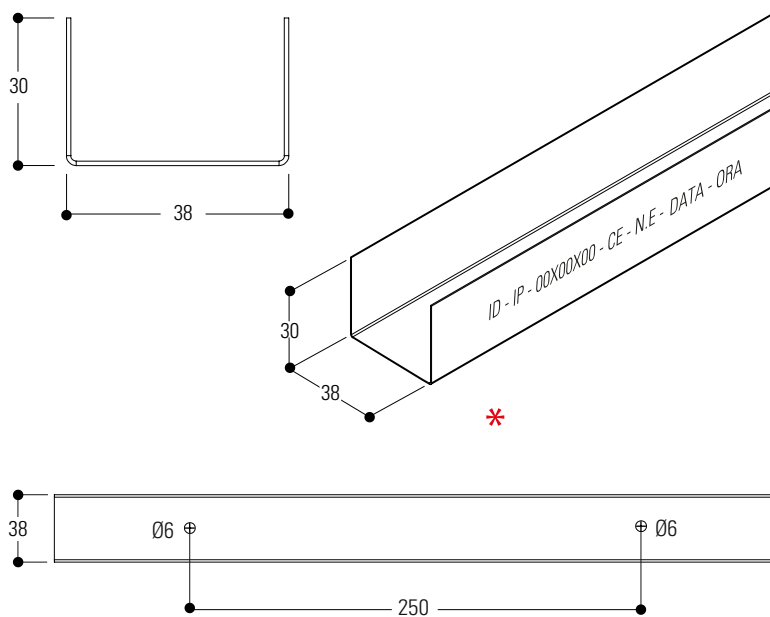

### GENERAL DESCRIPTION

The profile, with a U-shaped section with equal sides, is prevalently used as a rail for studs, omega profiles and as a perimeter profile. It is suitable for internal use and for the construction of false ceilings, self supporting walls and false ceilings with plasterboard cladding.

### MATERIAL USED

The profile is made of carbon steel type **DX51D Z100**, continuously hot-dip galvanized, with a yield strength of more than 300 N/mm<sup>2</sup> and defined by European standard EN 10346 with a zinc coating of 100 g/m<sup>2</sup> (higher weight on request). Additional coatings consist of:

- Zinc-aluminium type **DX51D+AZ**: this combination gives the profile excellent corrosion resistance, superior to that of galvanized steel profiles, making them suitable for both external and internal use.
- Zinc-magnesium type **DX51D+ZM**: This type of coating gives the profile an extraordinary degree of corrosion protection on the surface and is self-healing on the cut edges, making it suitable for even the harshest environments

### REPRESENTATION

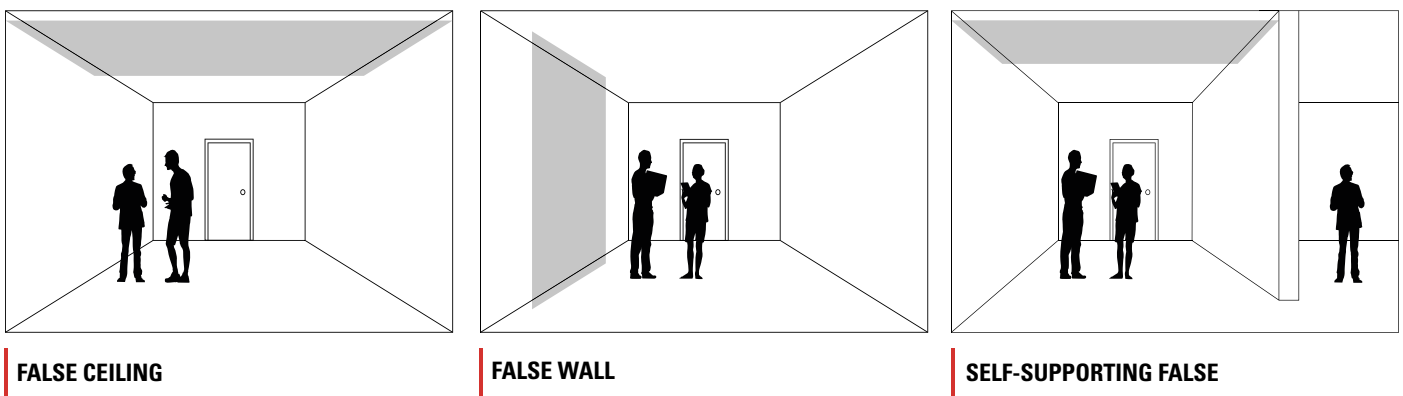

## ADVANTAGES AND APPLICATION UNI G30 PROFILE

---

The **G38** rail has superior versatility and features that make it competitive in its sector; it has 6 mm holes mounted at 250 mm pitch that give the rail a precise and adaptable fastening

- Profile suitable for application with **M29**
- Profile suitable for application with **SPO36**.

**\*The information marked individually by ink on the side of each profile are:**

GUERRASIO ID - PRODUCT IDENTIFICATION - DIMENSIONS - CE REGULATION - EUROPEAN NORM - DATE - TIME

### FASTENING TO THE FLOOR

### FASTENING TO THE PERIMETER

### FASTENING TO THE FLOOR

### FASTENING TO THE PERIMETER

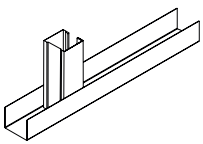

G38 with **M29**

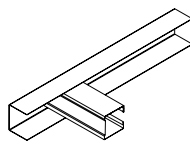

G38 with **M29**

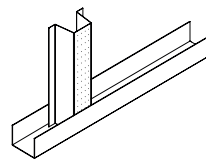

G38 with **SPO**

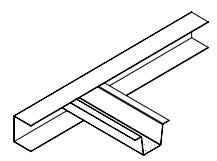

G38 with **SPO**

## NORMATIVE REFERENCES

---

- Construction product in accordance with Regulation (EU) 305/2011
- EC marking in accordance with EN 14195
- Sheet metal quality and coating grade in accordance with EN 10143 and EN 10346

## EC MARKING

---

The products listed in this catalogue are intended for use inside buildings. Each product is provided with a Declaration of Performance (DoP). Reaction to fire: class A1/Durability: class B (building components exposed to variable relative humidity up to 90% and variable temperatures up to 30°C but without corrosive contaminants, except class C5-M products).

## PRODUCT STORAGE

---

Store the packs in a covered areas with a relatively dry atmosphere and at a temperature as constant as possible, in order to avoid condensation which may reduce the state of passivation protecting the galvanised surface. If stored outdoors (not recommended), use a cover that provides perfect protection of the material against the weather (rain, fog, snow), taking care to place the packages at a slight angle. This cover must in any case be such as to allow adequate ventilation (not bringing the two surfaces into direct contact) so that moisture does not accumulate and create condensation.

## PACKAGING MATERIAL

---

The package is made with plastic strips. The pallet is made using plastic strips, wooden supports and laths. The packaging is suitably sized to facilitate handling in warehouses and on construction sites.

## TECHNICAL DATA

CHARACTERISTIC	REFERENCE NORM	VALUE	UNIT OF MEASUREMENT
Type	EN 14195	Metal structure	-
Reaction to fire	EN 14195-1A	1	-
Standard thickness	EN 10143	0,6 - 0,8	mm
Thickness tolerance	EN 10143	± 0,07	mm
Length	EN 14195	3000-4000	mm
Length tolerance	EN 14195	± 4	mm
Protective coating	EN 10346	5 ÷ 12	µm
Yield stress	EN 10143	340	N/mm <sup>2</sup>

## PACKING AND PALLET SHEET

### PACKAGING

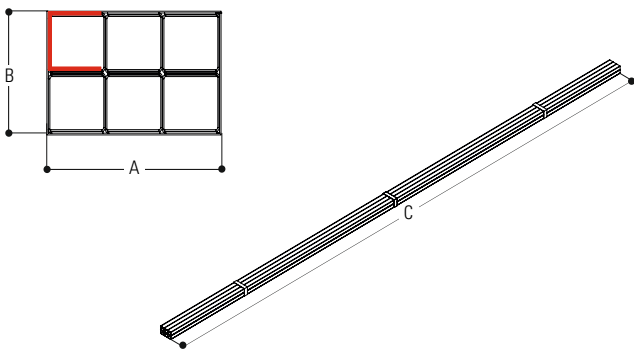

### PALLET

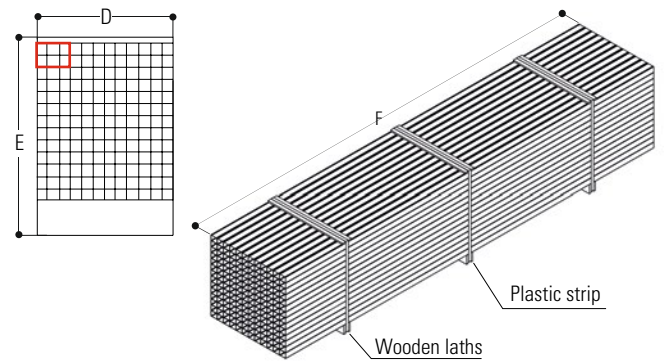

Profile weight	Kg/lm	0,456
	Kg/pc	1,368 (3 lm) 1,824 (4 lm)
Profile pieces	N°	12
Total per package	lm	36 (3 lm)
	Kg	16,40
	lm	48 (4 lm)
	Kg	21,90
Dimensions	mm	90 (a) 76 (b) 3000 (c) (3 lm)
		90 (a) 76 (b) 4000 (c) (4 lm)

Packages	Pcs	28
Total profiles	Pcs	336
Total per pallets	lm	1008 (3 lm)
	Kg	459
	lm	1344 (4 lm)
Dimensions	mm	490 (d) 530 (e) 3000 (f) (3 lm)
		490 (d) 530 (e) 4000 (f) (4 lm)

Total calculated on 6/10 thickness

**N.B.** -The weight of the package/pallet is subject to variation depending on the material tolerances described in the table.  
-All technical data and characteristics given in the data sheet are subject to change without notice.