

VERTEBRA® GV75

GENERAL DESCRIPTION

Flexible rail profile with articulated elements with 80 mm pitch, suitable as a rail for curved walls, arches in curved and linear walls and curved cladding for pillars. It is also used as a curved perimeter profile.

MATERIAL USED

The profile is made of carbon steel type DX51D Z100, continuously hot-dip galvanised, having a yield strength greater than 300 N/mm² and defined by European standard EN 10346 with zinc cladding of 100 g/m² (on request higher grammage).

Additional cladding consists of:

- Zinc-aluminium type **DX51D+AZ**: this combination gives the profile excellent corrosion resistance, superior to that of galvanised steel profiles, making them suitable for both indoor and outdoor use.
- Zinc-magnesium type **DX51D+ZM**: This type of cladding gives the profile an extraordinary degree of corrosion protection on the surface and is self-healing on the cut edges, making it suitable for even the harshest environments.

REPRESENTATION

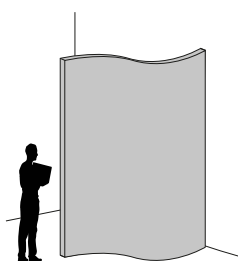

CURVE WALL

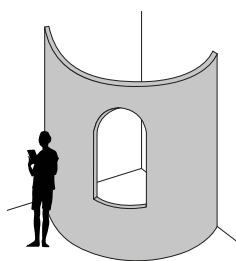

ARC IN CURVED WALL

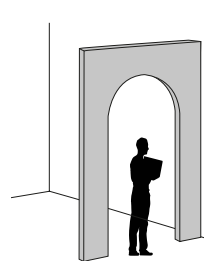

ARCH IN LINEAR WALL

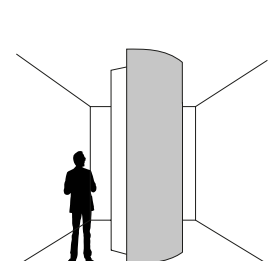

PILLAR CLADDING

ADVANTAGES AND APPLICATIONS GV75 PROFILE

The **GV75** rail, with its flexible geometry and structure, offers the possibility to easily create curved structural elements such as: curved walls, arches in curved and linear walls and cladding for pillars; adapting to any design requirement thanks to the 8 mm holes positioned at a pitch of 60 mm making application simple, easy and intuitive.

-Profile suitable for application with **M74** UNI and DIN

N.B the illustrations on the following pages are suitable for experienced and 'do it yourself' users

FIXING TO THE FLOOR

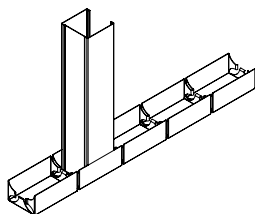

GV55 with **M54**

FIXING TO PERIMETER

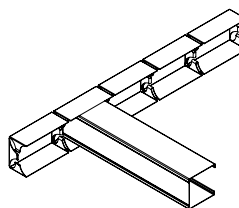

GV55 with **M54**

NORMATIVE REFERENCES

- Construction product according to Regulation (EU) 305/2011
- CE marking in accordance with EN 14195 and EN 13964
- Sheet metal quality and cladding grade in accordance with EN 10143 and EN 10346

CE MARKING

The products listed in this catalogue are intended for use inside buildings. Each product is provided with a Declaration of Performance (DoP). Reaction to fire: class A1/Durability: class B (building components exposed to variable relative humidity up to 90% and variable temperatures up to 30°C but without corrosive contaminants, except class C5-M products).

PRODUCT STORAGE

Store parcels in covered places with a relatively dry atmosphere and at a temperature as constant as possible in order to avoid condensation phenomena that may reduce the passivation state protecting the galvanised surface. If the material is stored outdoors (not recommended), use a cover that provides perfect protection against the weather (rain, fog, snow), taking care to place the packages at a slight angle. This cover must in any case be such as to allow adequate ventilation (not putting the two surfaces in direct contact), so that moisture does not accumulate and create condensation.

PACKAGING MATERIAL

The packaging is made with plastic strapping. The pallet is made of plastic strapping, wooden stand and laths. The packaging is suitably dimensioned to facilitate handling in warehouses and on construction sites. In the packaging the GV profiles are packed inside a rail profile.

CURVE WALL

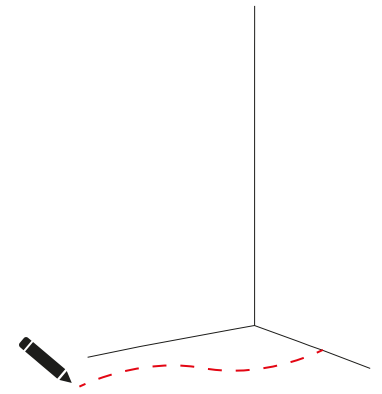
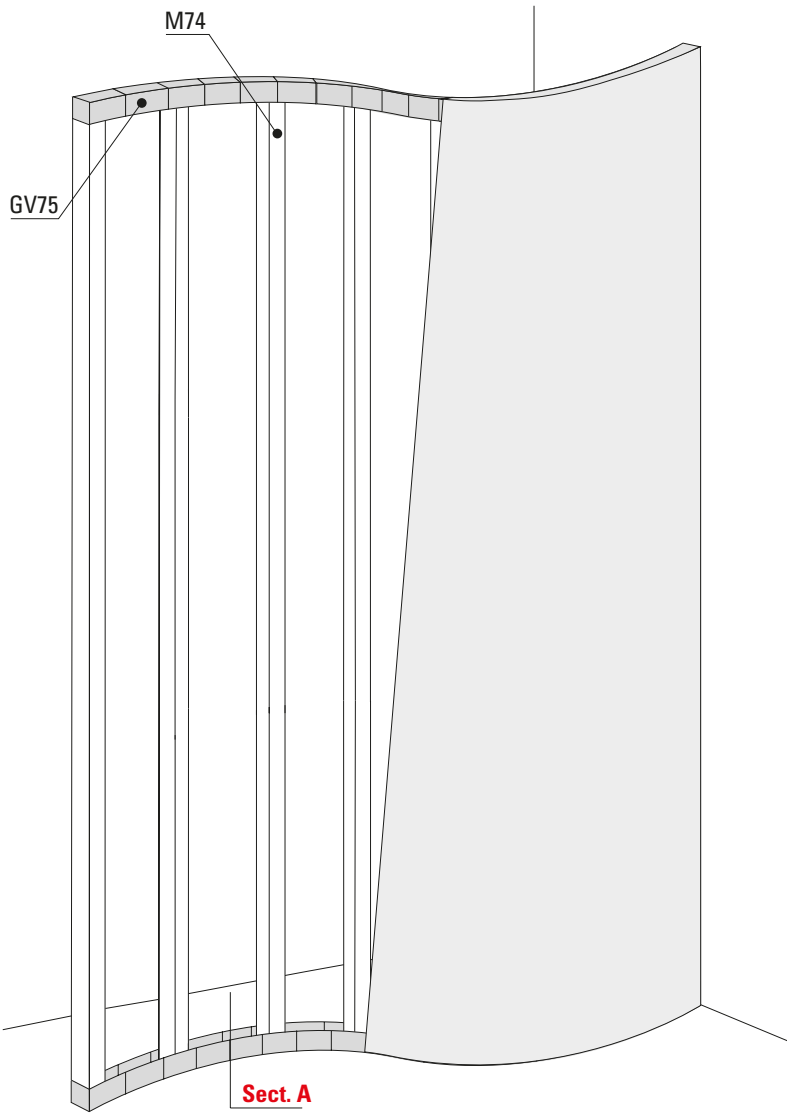

1. Draw lines to the floor and ceiling of the curved wall;

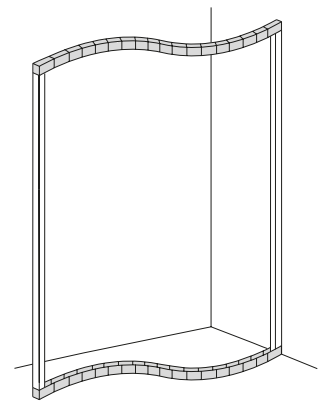

2. Shape the GV75 rail and fix it to the floor and to the ceiling;

4. In the final step, close the sides of the wall with 6 to 15 mm plasterboard panels.

N.B The pitch of the studs is adjusted according to the radius of curvature of the flexible rail. The tighter the rail radius, the tighter the studs fixing will be.

Sez. A

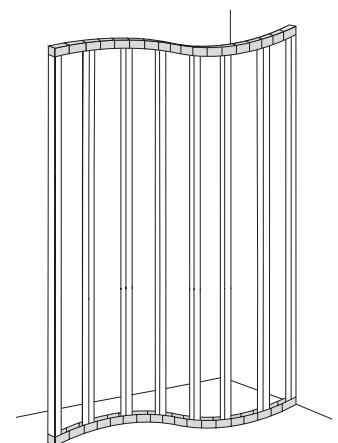
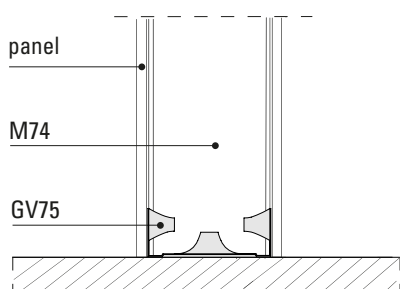

3. Insert M74 studs with a pitch suitable for the curvature radius and fix on GV75 rail;

ARCH IN CURVE WALL

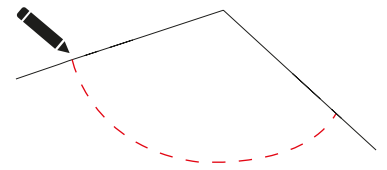
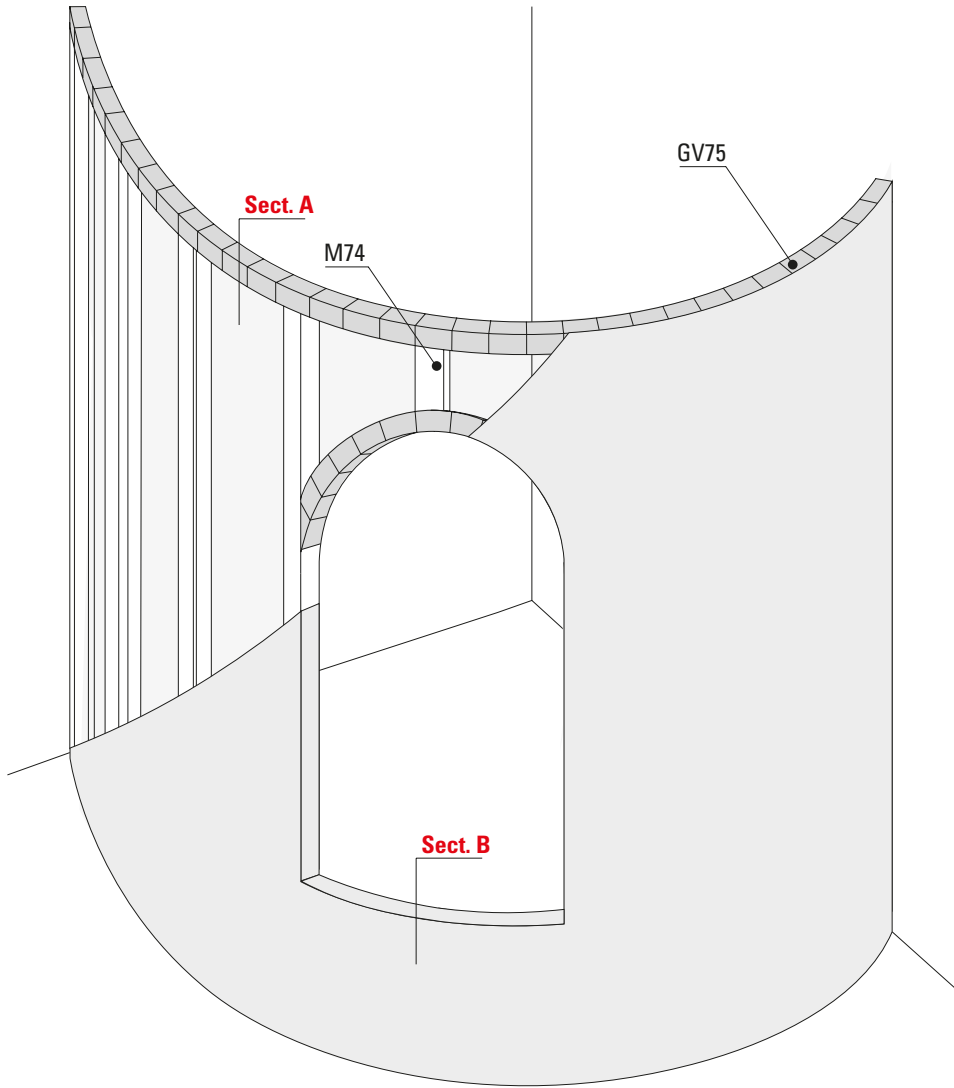

1. Draw lines on the floor and ceiling of the curved wall to be built;

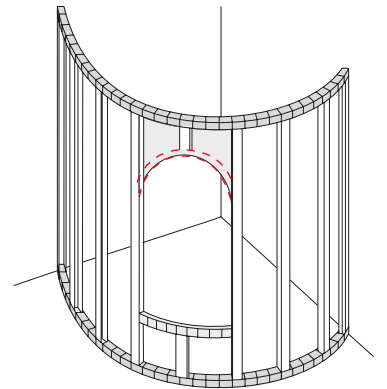

2. Shape and fix the GV75 rail on the floor and ceiling after determining the perfect level. Leave a free space to shape the GV75 rail with the help of a template cut out of plasterboard;

4. In the final step, close the sides of the wall with 6 to 15 mm plasterboard panels.

N.B The pitch of the studs is adjusted according to the radius of curvature of the flexible rail. The tighter the rail radius, the tighter the studs fixing will be.

Sect. A

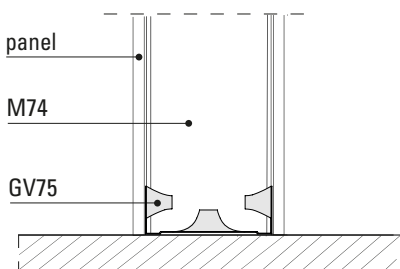

Sect. B

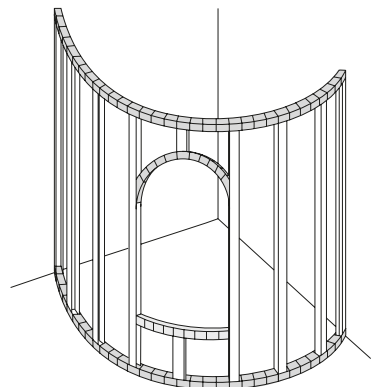
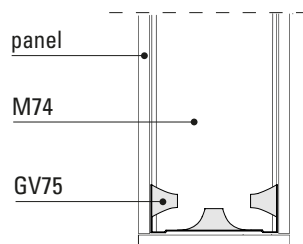

3. Complete the metal structure by fastening the M74 studs. Position one stud on the arch and then along the entire structure;

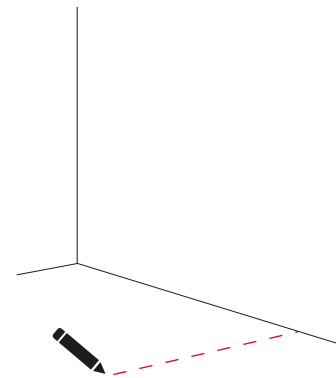
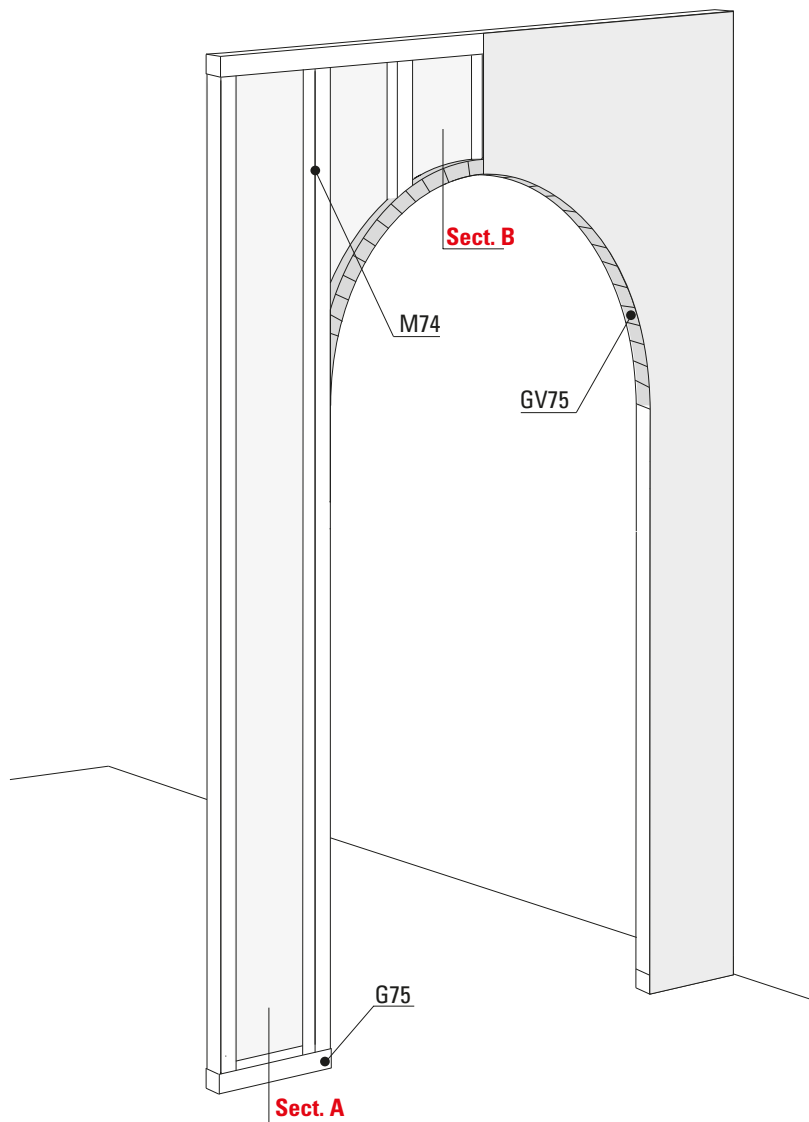

1. Fix the rails to the floor and ceiling by inserting M74 studs;

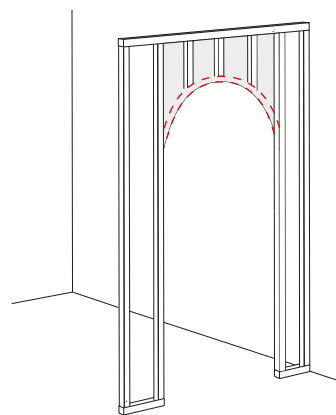

2. Leave space for insertion of the desired shape, position the plasterboard template made earlier and shape the GV75 rail onto it;

4. In the final step, close the sides of the wall with 6 to 15 mm plasterboard panels.

N.B The pitch of the studs is adjusted according to the radius of curvature of the flexible rail. The tighter the rail radius, the tighter the studs fixing will be.

Sect. A

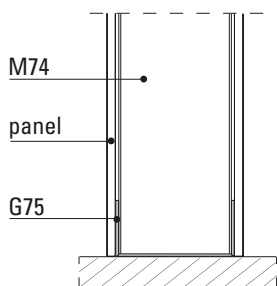

Sect. B

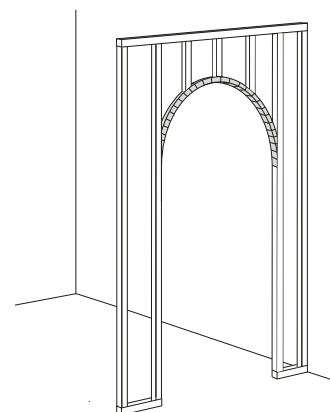
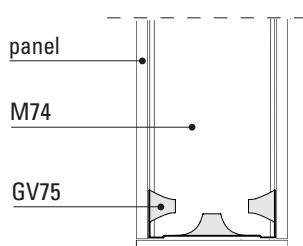

3. Shape and fix the GV75 rail inside the structure and complete by inserting the studs;

PILLAR CURVE CLADDING

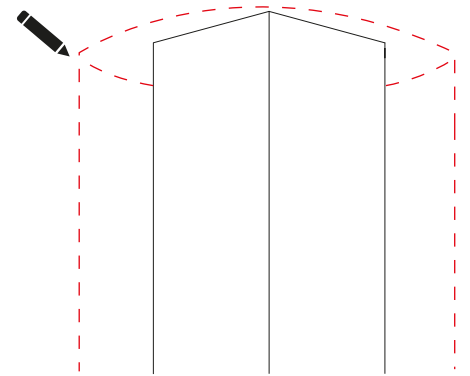
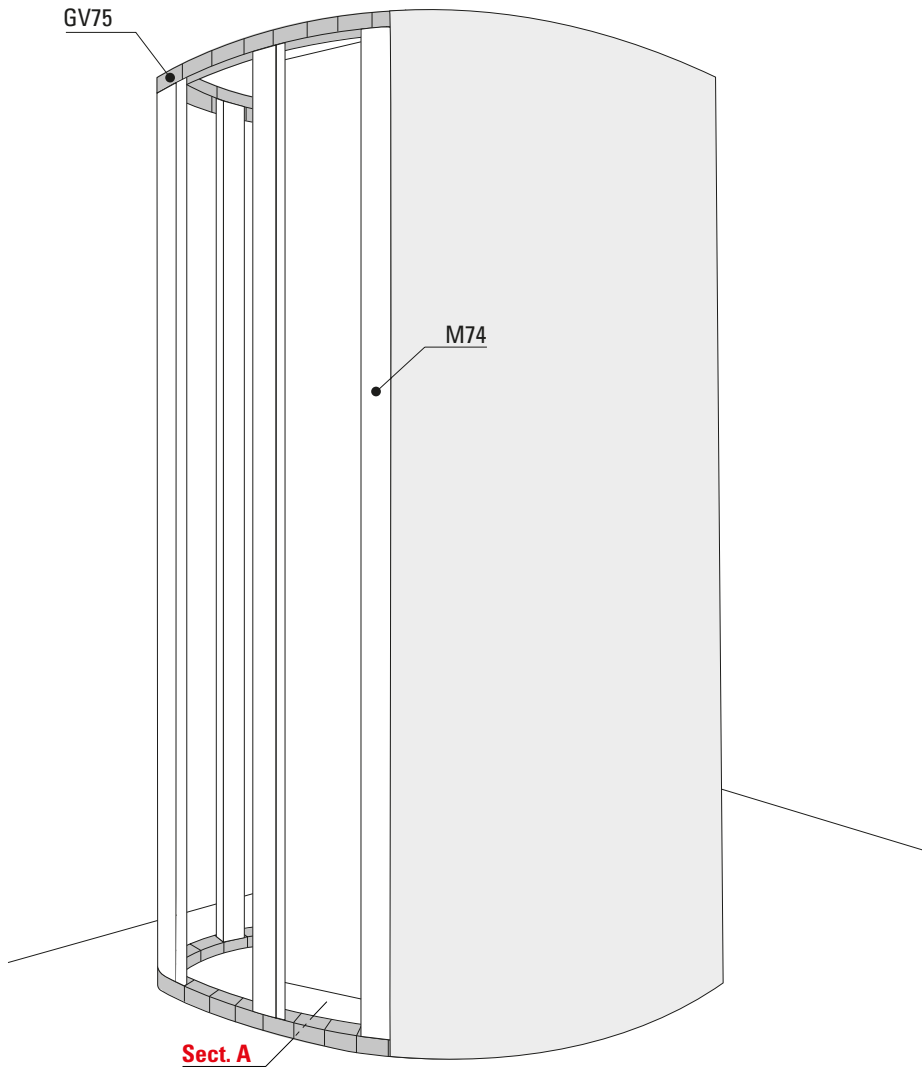

1. Draw the circular line of the floor covering on the floor and ceiling;

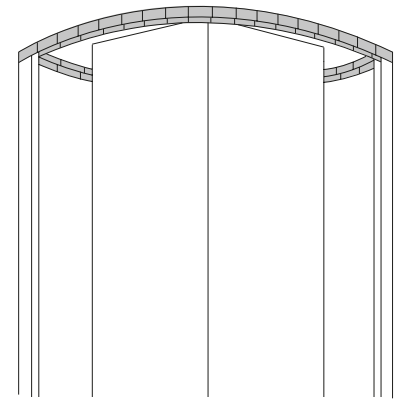

2. Shape and fix the GV75 rail to the floor and ceiling, then fix the M74 studs by positioning them between the rails;

4. In the final step, close the sides of the wall with 6 to 15 mm plasterboard panels.

N.B The pitch of the studs is adjusted according to the radius of curvature of the flexible rail. The tighter the rail radius, the tighter the studs fixing will be.

Sect. A

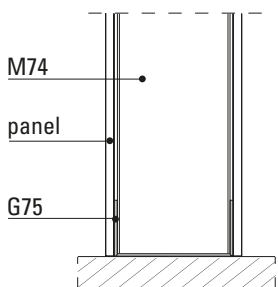

Sect. B

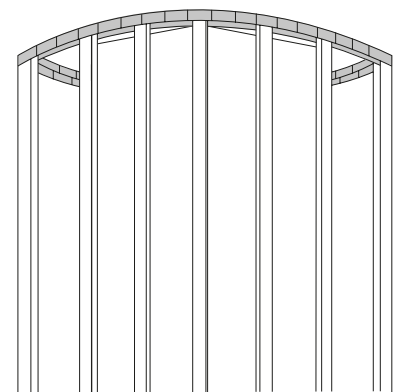
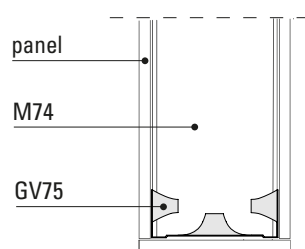

3. Complete the cladding by positioning the remaining studs along the entire metal structure;

DRAWING OF CIRCUMFERENCE AND ELLIPSE ARCS

In order to realise curved structures, curved lines or arcs must necessarily be drawn; the circumference arc is certainly the most commonly used. A circumference arc is called a '**round arc**' if it represents a semi-circumference; it is called a '**declined arc**' if it is drawn only in part, i.e. if the distance between the ends of the arc (called the '**chord**') is less than the diameter; while an '**arrow**' is defined as the maximum distance of the chord from the semi-circumference.

Tracing the arc of a circumference by three points:

- The points are joined to obtain the segments AB and BC;
- The midpoints, called segments, are determined;
- The perpendicular bisectors through the midpoints are extended until they intersect at point O;
- The arc of a circle with centre O and radius r equal to the segment OC is drawn.

This case often occurs on construction sites when a barrel vault is to be built in a corridor, for example; the starting point of the vault is called the **impost height**, while the highest point is called the **vault height**.

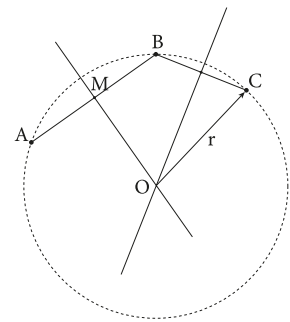
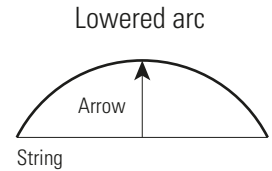
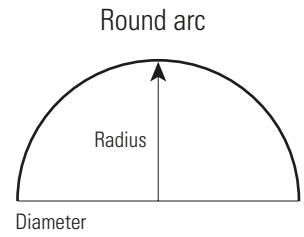

Drawing the ellipse using the "gardener's method"

In order to draw the **ellipse**, two particular points, called "focuses", are needed, which are positioned on the **major axis** and are at the same distance from the centre of the ellipse, point of intersection of the major and **minor axes**.

We take a string of length equal to half the major axis and point it at C, tracing an arc of circumference that intersects AB at points F1 and F2; A string of a length equal to the major axis AB is taken; the ends are tied to two nails fixed at F1 and F2; With a pencil, the string is stretched and the ellipse is drawn.

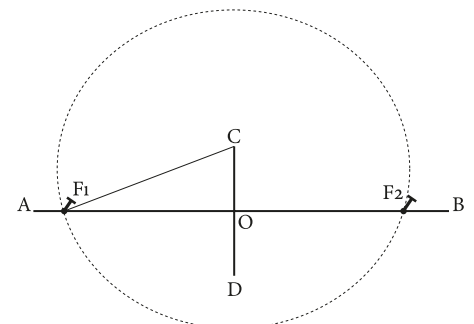
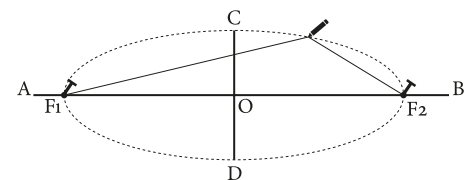
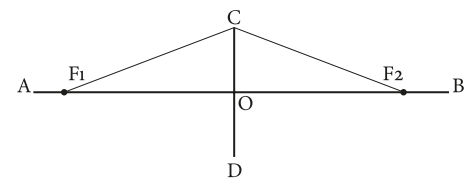

- AB= major axis**
- CD= minor axis**
- F1 e F2= focuses**
- CF1= AO**

MIN. RADIUS CURVATURE

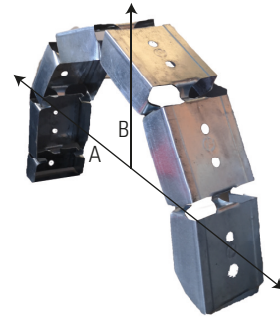
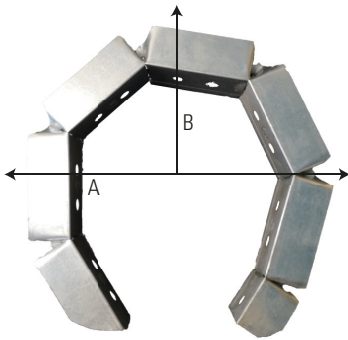

Diameter A: 27 cm Radius B: 13 cm

MIN. RADIUS DORSAL CURVATURE

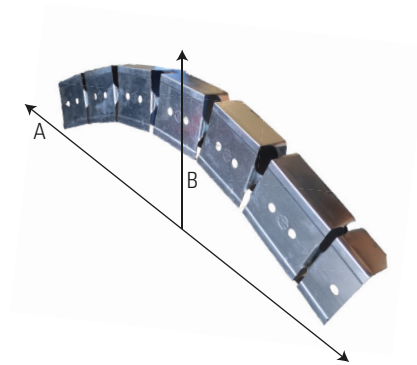
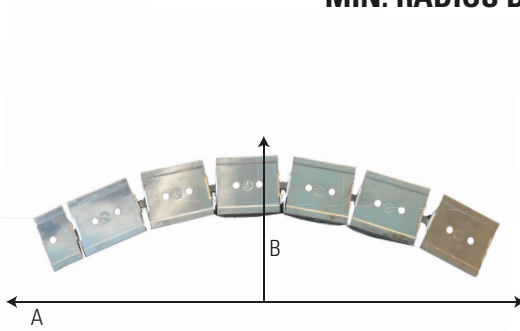

Diameter A: 90 cm Radius B: 45 cm

TYPES OF ARCS WITH NOMENCLATURES AND CENTRES

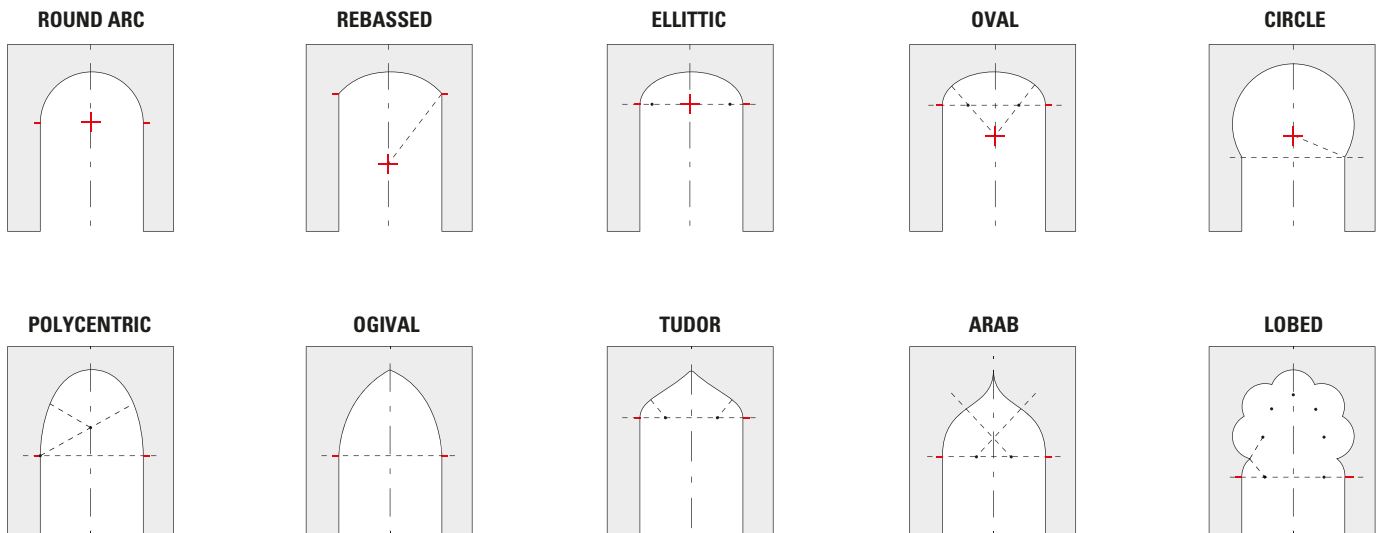

TECHNICAL DATA

CHARACTERISTIC	REFERENCE STANDARD	VALUE	UNIT OF MEASUREMENT
Type	EN 14195	Metal structure	-
Reaction to fire	EN 14195-1A	1	
Thickness	EN 10143	0,6 - 0,8	mm
Thickness tolerance	EN 10143	± 0,07	mm
Length	EN 14195	3000	mm
Length tolerance	EN 14195	± 4	mm
Protective cladding	EN 10346	5 ÷ 12	µm
Yield stress	EN 10143	340	N/mm ²

PACKAGING AND PALLET SHEET

PACKAGING

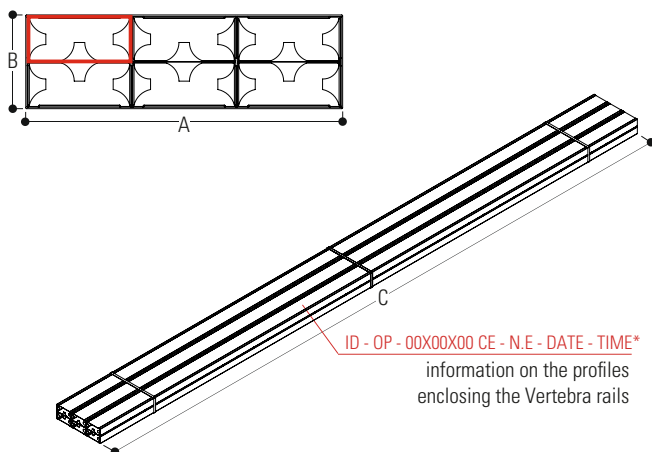

Profile weight	Kg/m	0,662	3 m	
	Kg/pc	1,986		
Profile pieces	Pcs	6		
Total per package	m	18	3 m	
	Kg	23,80		
Dimensions	mm	230	3000	
		70		3 m
		a	b	c

PALLET

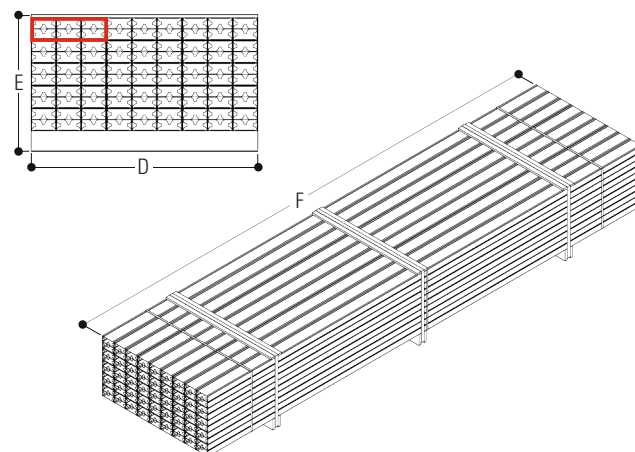

Packaging	Pcs	15		
Total profiles	Pcs	90		
Total per package	m	270	3 m	
	Kg	356		
Dimensions	mm	690	3000	
		410		3 m
		d	e	f

Weight calculated on thickness 6/10

- N.B.** - The weight of the package/pallet is subject to variation depending on the material tolerances described in the table.
- The total weight of the pallet also includes the value of the rails used to wrap the main profiles in the pack.
 - All technical data and specifications in the data sheet are subject to change without notice.

PACKAGING

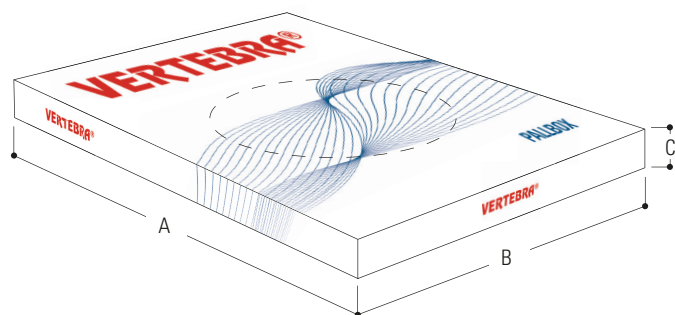

Profile weight	Kg/m	0,662	20 m
	Kg/pc		
Profile pieces	Pcs	1	
Total per package	m	20	
	Kg	14,00	
Dimensions	mm	1150	90
		720	
		a b c	

PALLBOX

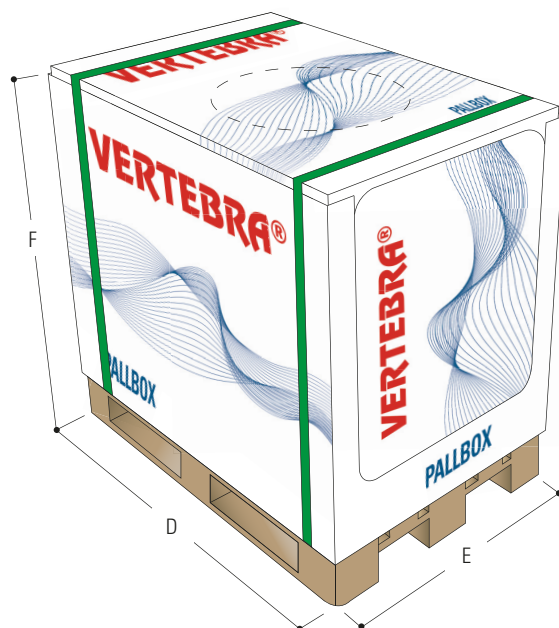

Packaging	Pcs	10
Total profiles	Pcs	10
Total per package	m	200
	Kg	160
Dimensions	mm	1200
		780
		d e f

Weight calculated on thickness 6/10

- The pallbox is placed on a Euro pallet, secured with strapping and protected with stretch film.
- The VERTEBRA profiles contained in the pallboxes are made of galvanised steel DX51D with a thickness of 0.6 mm.