

# DIN M54A

## Stud

### GENERAL DESCRIPTION

The profile, with a 'C' section, is mainly used as a stud mounted on UNI and DIN standard rails. Suitable for interior use and for the construction of false ceilings, false walls, linear walls and curved walls with plasterboard cladding.

### MATERIAL USED

The profile is made of carbon steel type DX51D Z100, continuously hot-dip galvanised, with a yield strength greater than 300 N/mm<sup>2</sup> and defined by European standard EN 10346 with a zinc cladding of 100 g/m<sup>2</sup> (higher grammage on request).

Additional claddings consist of:

- Zinc-aluminium type **DX51D+AZ**: this combination gives the profile excellent corrosion resistance, superior to that of galvanised steel profiles, making them suitable for both indoor and outdoor use.
- Zinc-magnesium type **DX51D+ZM**: This type of cladding gives the profile an extraordinary degree of corrosion protection on the surface and is self-healing on the cut edges, making it suitable for even the harshest environments.

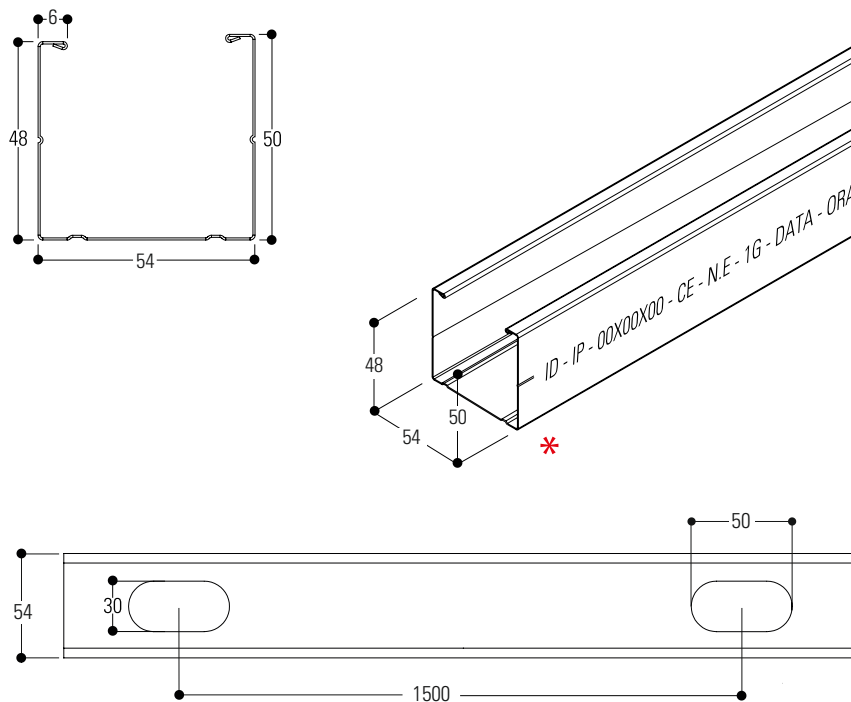

### REPRESENTATION

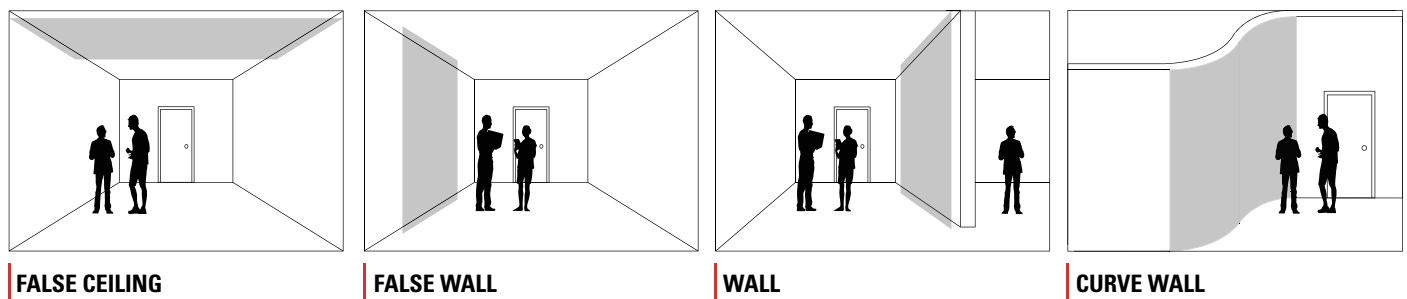

## STUD M54A ADVANTAGES AND APPLICATIONS

---

The **M54A** stud has superior versatility and features that make it advantageous in its sector, thanks to the 30x50 mm slots mounted at 1500 mm pitch that give the stud a smooth passage for cables. It is ideal for constructing load-bearing frames to support single or double frame plasterboard walls with single or multiple claddings.

- Profile suitable for application with **G55** UNI and DIN
- Profile suitable for snap-on extension with **M54A**
- Profile suitable for application with **GV55**

**\*The information marked individually in ink on the side of each profile are:**

GUERRASIO ID - PRODUCT IDENTIFIER - DIMENSIONS - REGULATION CE - EUROPEAN STANDARD - DATE - TIME

### FIXING TO THE FLOOR

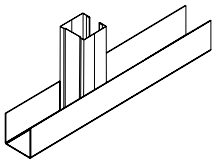

M54 with **G55**

### FIXING TO PERIMETER

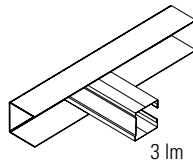

M54 with **G55**

### EXTENSION

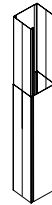

M54 with **M54A**

### FIXING TO THE FLOOR

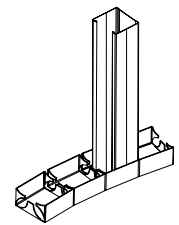

M54 with **GV55**

## NORMATIVE REFERENCES

---

- Construction product according to Regulation (EU) 305/2011
- EC marking in accordance with EN 14195
- Sheet metal quality and cladding grade according to EN 10143 and EN 10346
- Product according to DIN 12182

## EC MARKING

---

The products listed in this catalogue are intended for indoor use. Each product is provided with a Declaration of Performance (DoP). Reaction to fire: class A1/Durability: class B (building components exposed to variable relative humidity up to 90% and variable temperatures up to 30°C but without corrosive contaminants, except class C5-M products).

## PRODUCT STORAGE

---

Store parcels in covered places with a relatively dry atmosphere and at a temperature as constant as possible in order to avoid condensation phenomena that may reduce the passivation state protecting the galvanised surface. In the case of outdoor storage (not recommended), use a cover that perfectly protects the material against the weather (rain, fog, snow), taking care to place the packages at a slight angle. This cover must in any case be such as to allow adequate ventilation (not putting the two surfaces in direct contact), so that moisture does not accumulate and create condensation.

## PACKAGING MATERIAL

---

The packaging is made with plastic strapping. The pallet is made with plastic strapping, wooden support and laths. The packaging is suitably dimensioned to facilitate handling in warehouses and on construction sites

## TECHNICAL DATA

CHARACTERISTIC	REFERENCE NORM	VALUE	UNIT OF MEASUREMENT
Type	EN 14195	Metal structure	-
Reaction to fire	EN 14195-1A	1	-
Standard thickness	EN 10143	0,6 - 0,8	mm
Thickness tolerance	EN 10143	± 0,07	mm
Length	EN 14195	3000-4000	mm
Length tolerance	EN 14195	± 4	mm
Protective coating	EN 10346	5 ÷ 12	µm
Yield stress	EN 10143	335	N/mm <sup>2</sup>

## PACKING AND PALLET SHEET

### PACKAGING

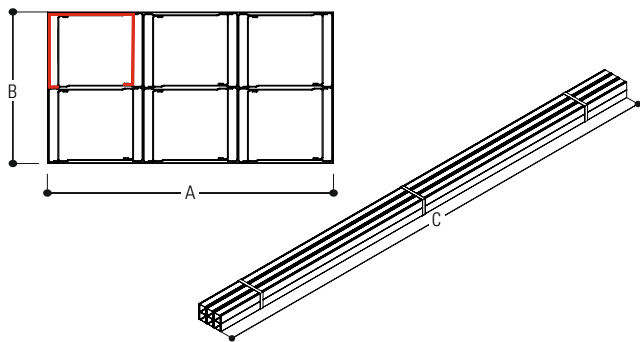

### PALLET

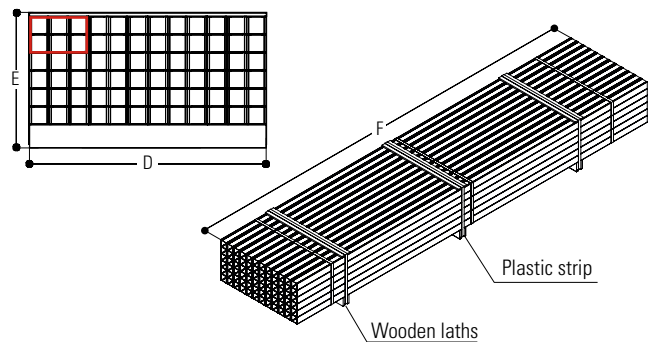

Profile weight	Kg/lm	0,782
	Kg/pc	2,346      3,128
Profile pieces	N°	12
Total per package	lm	36      3 lm
	Kg	28,15
	lm	48      4 lm
	Kg	37,53
Dimensions	mm	180   100   3000      3 lm
		a      b      c
		180   100   4000      4 lm
		a      b      c

Packages	Pcs	12
Total profiles	Pcs	144
Total per pallets	lm	432      3 lm
	Kg	338
	lm	576      4 lm
Dimensions	mm	560   500   3000      3 lm
		d      e      f
		560   500   4000      4 lm
		d      e      f

Total calculated on thickness 6/10

**N.B.** -The weight of the package/pallet is subject to variation depending on the material tolerances described in the table.  
-All technical data and characteristics given in the data sheet are subject to change without notice.